

LLC «Element»



iTap-2 PRO: no-foam bottling device

Passport and manual

Basic information	2
Technical details and configuration	3
Scheme	4
Installation	5
Height regulation	6
Bottle filling instruction	7
Maintenance routine	9
Device specification	10
Warranty	11
Acceptance and packaging certificates	12
Contacts	13

This Passport and Manual is designed to provide information about the construction and work of a no-foam bottling device AP-16.00.000 (or the device), installation, exploitation, and maintenance.

The user has to develop a detailed instruction for exploitation, accident prevention, electric safety, safety of labour, and maintenance, based on this passport.

ATTENTION! The manufacturer can alter the device construction due to the technological progress.

iTap-2 PRO: no-foam bottling device

Serial number: _____

Production date: _____

Manufacturer: LLC «Element»

The bottling device is designed for no-foam filling of glass bottles with the following dimensions: height from 150-450 mm, outer diameter of the bottleneck from 25-50 mm. The bottles can be filled with 2 types of foamy drinks of choice, the maximum pressure allowed is 0.2 MPa. The device can be used at the temperature from +5°C to +40°C.

Parameter	Value
Max nominal productivity (bottles per hour) for bottles up to 0.5 litre	180
Operating pressure entering the device (MPa)	0,05– 0,2
Power Volt (V)	~110-220
Power consumption (Watt)	12
Max total weight (kg)	6,5
Max dimensions (mm):	
height	680
width	240
length	260

Unit	Identification	Quantity
Bottling device	AP-16.00.000	1
Passport	AP-16.00.000 ПС	1
Set of spare parts	AP-16.00.000 ЗИП	1
Power supply adapter	AC/DC Adapter	1

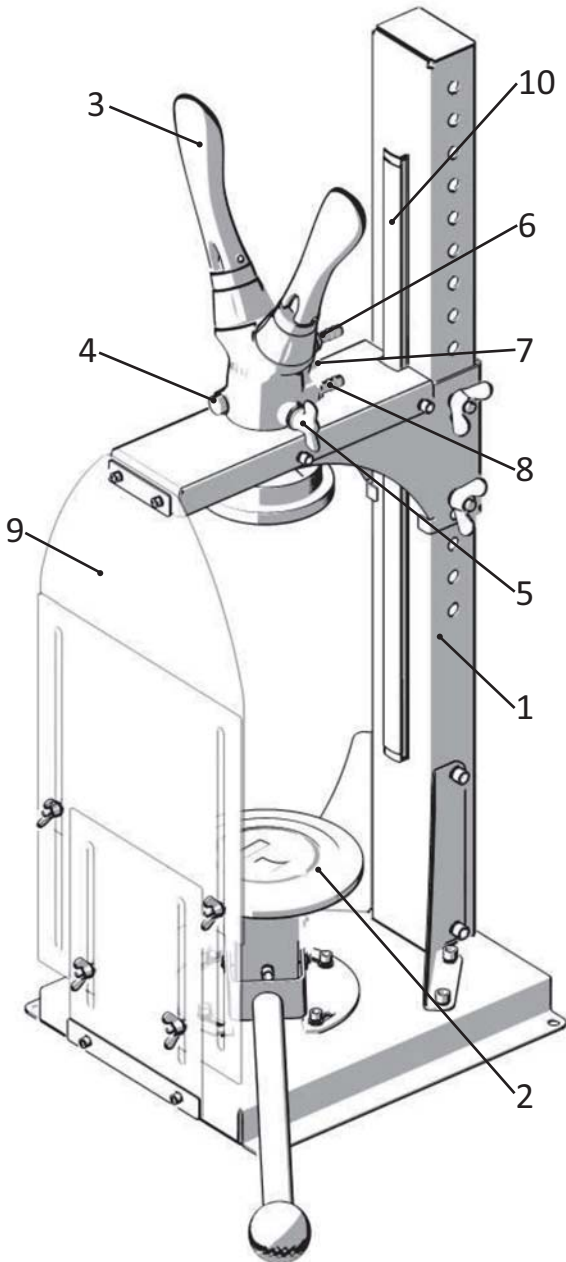

1 - Body

2 - Bottle pressing mechanism

3 - Beverage supply handle

4 - CO₂ feed button

5 - Throttle knob

6 - Drink supply nipple

7 - CO₂ supply nipple

8 - Drainage nipple

9 - Protection screen

10 - LED illumination

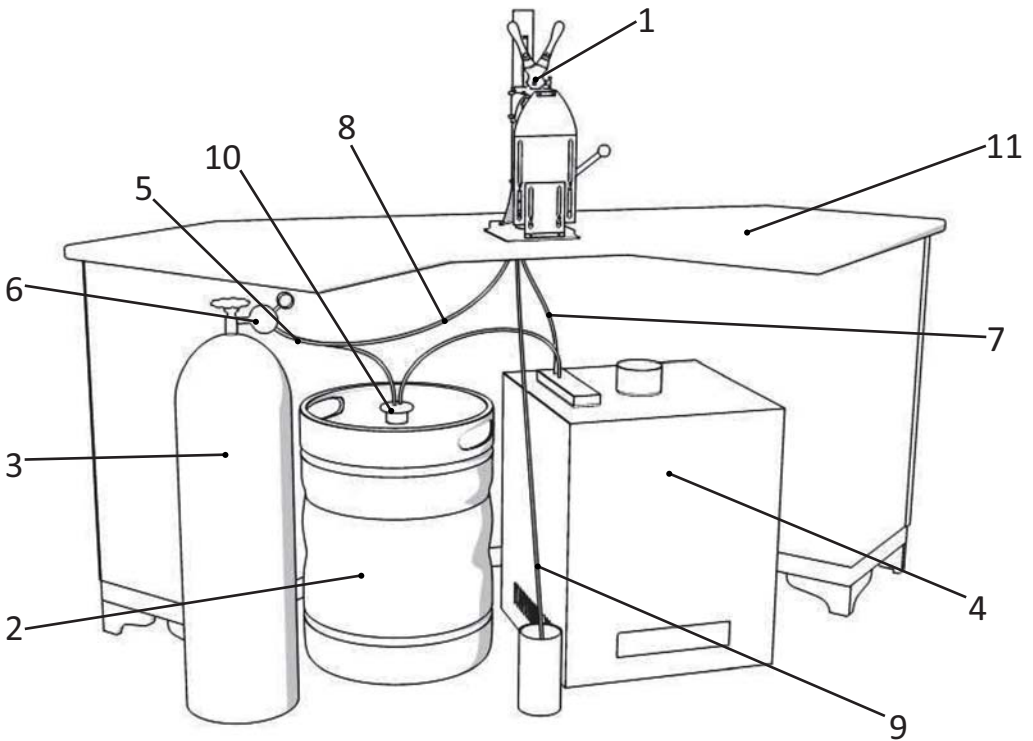

1 - Device

7 - Drink supply hose

2 - Keg with a beverage

8 - CO₂ supply hose

3 - CO₂ gas cylinder

9 - Drainage hose

4 - Cooler

10 - Intake cap

5 - Triple adaptor

11 - Counter

6 - Reductor

1. Place the bottle (3) on the base (2).
2. Free the bracket (4) by screwing off the nuts (5) and putting away the pins (6).
3. Lower the bracket (4) with the tap (7) on the bottleneck (3).
4. Using the lever (1) lower the bottle (3) and the bracket (4) for the maximum bottleneck (3) pressure against the tap (7), while the bottle can be easily released from the bottling zone.
5. Fixate the bracket (4) with the pins (6) and nuts (5).

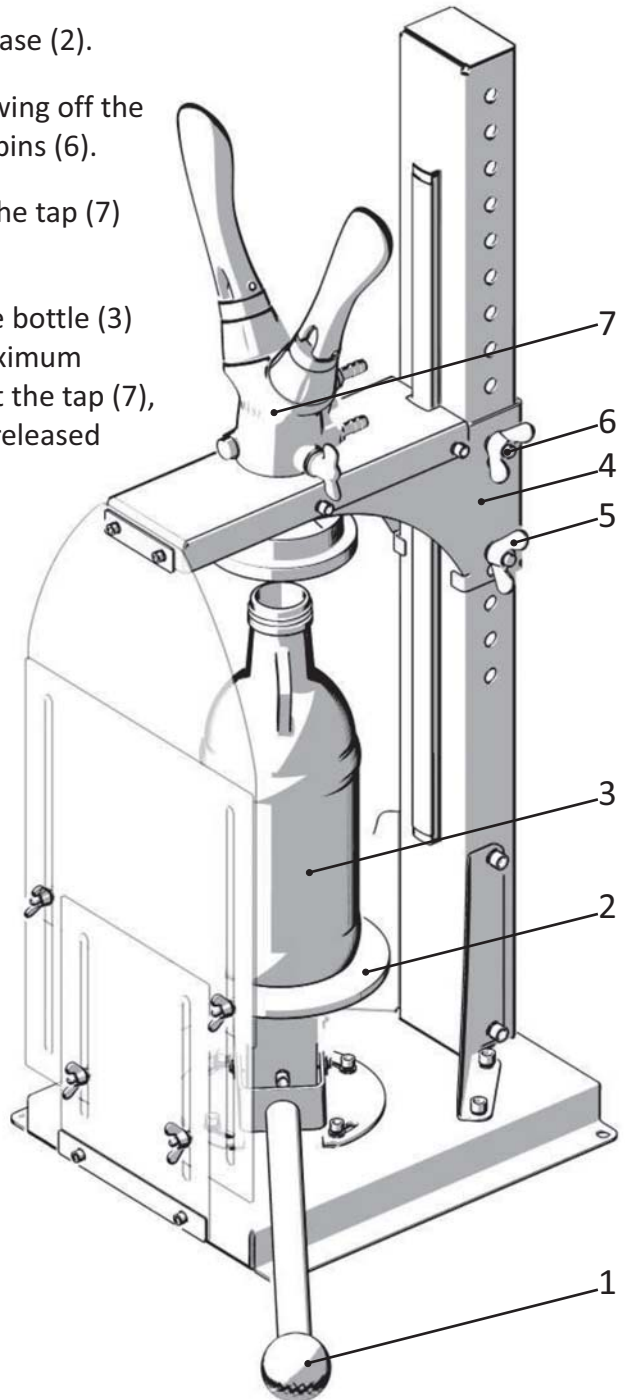

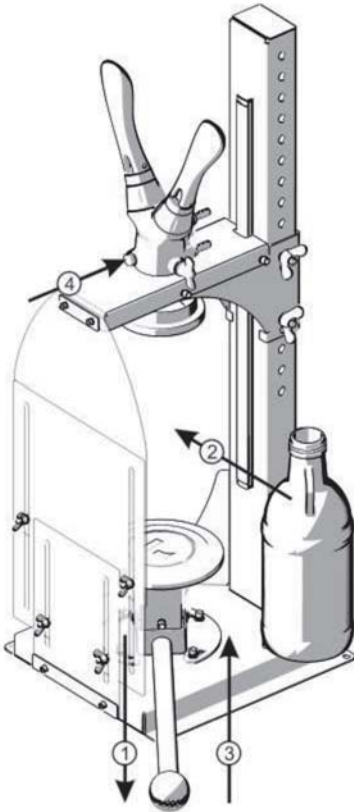

- ① Move the lever to the lowest position.
- ② Place the bottle on the base.
- ③ Stop holding the lever, the spring will press the bottle against the tap.
- ④ Push the CO₂ feed button to purge the bottles.

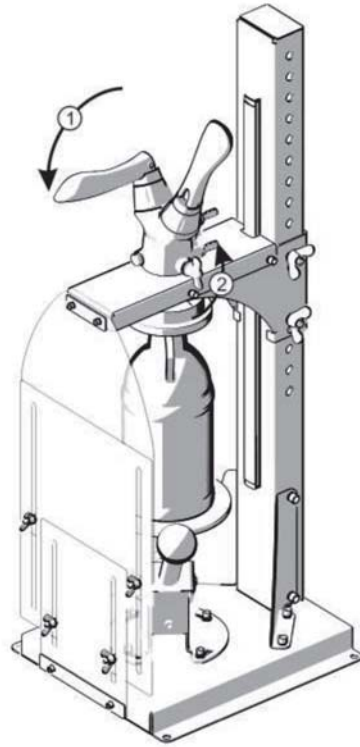

- ① Turn the handle 90°, to open the beverage serving valve.
- ② Turn the throttle knob counter clockwise. The beverage will pour into the bottle. Regulate the filling speed by turning the throttle knob.

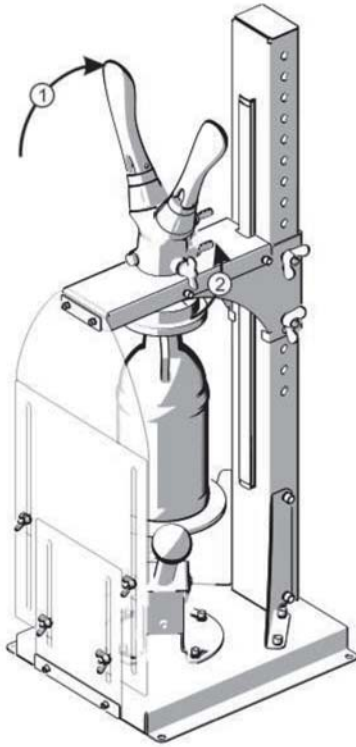

- ① When the bottle is filled, turn the handle 90°, into the vertical position.
- ② Fully open the throttle to level the pressure in and outside the bottle, by turning the knob counter clockwise to the limit.

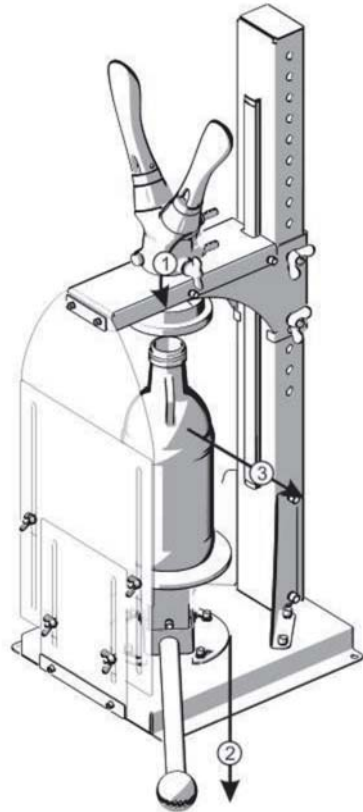

- ① Close the throttle by turning the knob clockwise to the limit.
- ② Move the lever to the lowest position.
- ③ Remove the bottle.

The device maintenance has to be done by the employees who read the manual and are familiar with the safety protocol for working with the drinks pouring equipment.

Type of work	Frequency	Solution	Time (min)	t (°C)	Solution Source
Wash	Once a day (in the end of a day)	Water	10	60	Tap water
Rinse		Water	15	20	Tap water
Disinfection	Once a week	Detergent for food equipment disinfection	10-15	60	Single use container
Rinse	After disinfection	Water	10	40-60	Tap water
Rinse		Water	15	20	Tap water

The cleaning method for iTap dispenser.

According to the beer and drinks production standards, the pouring device must be cleaned daily for 30 minutes in hot (60°C) and cold water.

The device must be disinfected weekly using an antiseptic detergent, and then thoroughly washed in cold water to fully remove the detergent.

If the device is used for commercial purposes, it has to be disinfected after every use.

Safety measures

To ensure the flawless device operation you should follow the certain rules:

- Don't use the device without the protection screen.
- Don't use defected bottles.
- Don't set the pressure in the device higher than 0.2 MPa.

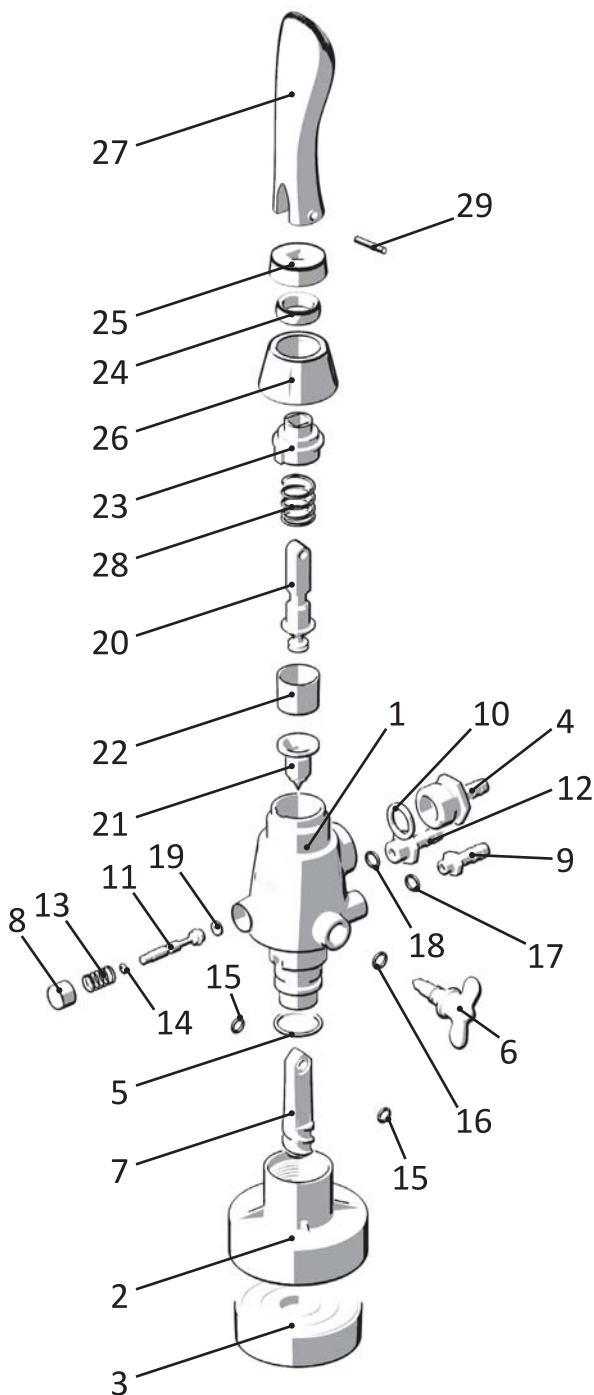

Поз.	Обозначение	Наименование
1	AP-16.01.000	Tap body
2	AP-15.00.007	Plug
3	AP-15.00.008	Seal
4	AP-15.00.030	Ring
5	AP-01.05.000	Throttle knob
6	AP-01.00.001	Screw
7	AP-01.00.002	Button
8	AP-01.00.005	Nipple
9	AP-01.00.008	Handle stock
10	AP-01.00.009	Nipple
11	AP-01.00.011	Spring
12	AP-01.00.031	Ring
13	AP-01.00.032	Ring
14	AP-01.00.033	Ring
15	AP-01.00.034	Ring
16	AP-01.00.035	Ring
17	AP-01.00.036	Ring
18	AP-01.02.001	Handle stock
19	AP-01.02.002	Valve
20	AP-01.02.003	Ring
21	AP-01.02.004	Plug
22	AP-01.02.005	Ring
23	AP-01.02.006	Cap
24	AP-01.02.007	Nut
25	AP-01.02.008	Handle
26	AP-01.02.009	Spring
27	DIN7 4x28-St	Pin

The manufacturer ensures the device correspondence to the technical documentation requirements if the user follows the terms of exploitation, transportation, and storage.

The warranty period is 12 months after the purchase.

The exploitation start date is determined by the date of signing the acceptance act by the authorised representatives of the manufacturing company and the consuming company.

The manufacturer guarantees a non-repayable correction of defects in the shortest technically possible period of time, and replacement of worn out parts during the warranty period.

In case a fault is identified during the warranty period or if the device configuration was not complete at the moment of purchase, the buyer has to submit a claim to the manufacturing company. The point of reclamation has to be presented in a form specified in the «Reclamation registration» section of this passport. The claim has to be sent to the manufacturer.

The claims are not accepted:

- after the warranty period ended
- if the consumer violated the rules of exploitation, storage, transportation listed in the exploitation documentation and Specification.

iTap-2 PRO: no-foam bottling device _____
serial number

**Manufactured and accepted according to the functioning Specification
28.29.21-001-52851405-2020 and classified fit for exploitation.**

Chief of QCD _____
seal signature printed name date

Packaged according to the functioning technical documentation

_____ _____ _____ _____
title signature printed name date

<https://boel.company/>
E-mail: boel.shop@gmail.com
+ 7-913-894-53-95

Address:
Nighegorodskaya St. 270/5
630063 Novosibirsk, Russia

